

COMPANY PROFILE



LOVATO Electric headquarters - Bergamo (ITALY)



CUTTING EDGE TECHNOLOGY

An **innovative product** is created with technologically advanced processes: the efficiency of our processes is assured by our continuous investments in **digitalisation, robotics and automation**, which enable us to guarantee the highest quality of our large scale production.



TOTAL QUALITY

LOVATO Electric is equipped with modern measurement systems (including multi-sensor, coordinate-based and tomographic systems) conforming with the most varied and stringent quality requirements; it employs product validation (PPAP), risk analysis (FMEA) and problem solving (8D) methods to guarantee reliability and improve our processes and products.

- Energy management **UNI CEI EN ISO 50001:2018**
- Environmental Management **UNI EN ISO 14001:2015**
- Occupational health and safety **UNI ISO 45001:2018**
- Quality Management **ISO 9001:2015**



Our R&D laboratory has a total area of 2,100 m². It is conforming with the international **EN/ISO/IEC 17025** standard and is accredited with the major international bodies, including **ACAIE** and **IMQ**, for product certification testing.

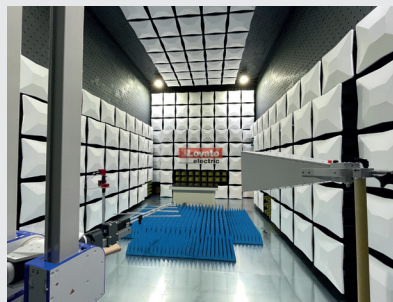

MARKET LEADER SINCE 1922

Established in Bergamo in 1922, **LOVATO Electric** is a private company run by the same family for 4 generations. For over 100 years, **LOVATO Electric** has been designing and manufacturing low voltage electrical components for industrial applications. We now offer more than 21,000 products conforming with the most stringent international certifications.



ITALIAN DESIGN

Italian design has always been our hallmark: our designers, researchers and engineering experts work in our Bergamo offices.

RESEARCH AND DEVELOPMENT

At our Bergamo offices, using the most modern software and technology available, our team of expert designers and researchers develop **innovative** and **reliable** products.

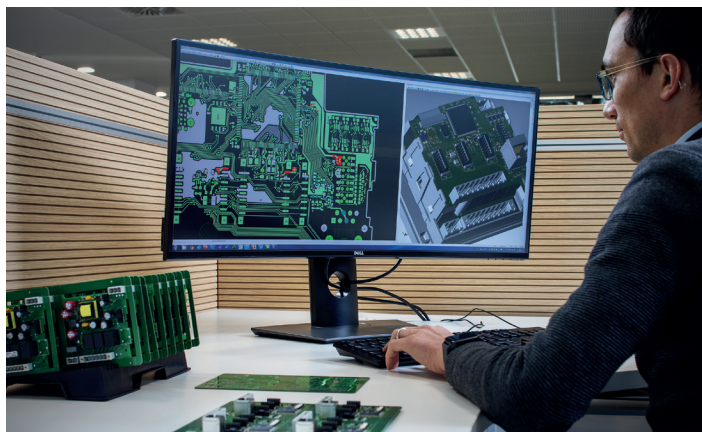
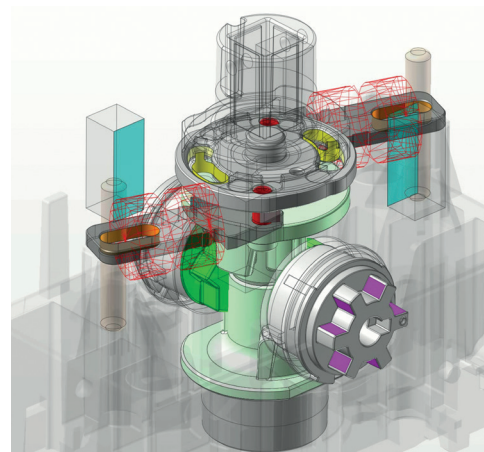

MOTOR PROTECTION AND CONTROL



Motor protection circuit breakers



Contactors

CONTROL AND SIGNALLING



Pushbutton and selector switches



Signal towers and beacons

CIRCUIT PROTECTION AND ISOLATION



Moulded case circuit breakers



Switch disconnectors

AUTOMATION AND CONTROL



Time relays



Monitoring relays

ENERGY MANAGEMENT



Energy meters and power analyzers



Current transformers



Motor protection relays



Electronic and electromechanical starters



Soft starters



Variable speed drives



Solid state relays

5 GROUPS

36 PRODUCT FAMILIES

21,000 CODES



Limit, micro and foot switches



Safety devices



Rotary cam switches



Power distribution blocks



Fuse holders and fuses



Miniature and residual circuit breakers



Surge protection devices



Modular contactors and other modular devices



Earth leakage relays



Level control and float switches



General purpose relays



Micro PLCs and HMI



Switching power supplies



Automatic battery chargers



Power factor controllers and thyristor modules



Automatic transfer switch controllers



Engine and generator controllers



Fire pump controllers



Communication devices



Expansion modules and accessories



Software and Apps

A WIDE RANGE OF PRODUCTS AND SERVICES

Our mission is to provide products and services for **industrial automation** and **energy management**.



APPLICATIONS

ENERGY
MANAGEMENT



MACHINE
BUILDERS (OEMS)



LIFTING
SYSTEMS



PHOTOVOLTAIC
SYSTEMS



PUMPS,
IRRIGATION
AND PIPING



GENERATORS



ELECTRICAL
POWER DISTRIBUTION



POWER FACTOR
CORRECTION



E-MOBILITY





100 COUNTRIES

16 COMPANIES

90 IMPORTERS

IT **Italy (Headquarters)**
LOVATO ELECTRIC S.P.A.

UK **United Kingdom**
LOVATO ELECTRIC LTD

F **France**
LOVATO ELECTRIC SAS

PL **Poland**
LOVATO ELECTRIC SP. Z O.O.

CN **China**
LOVATO ELECTRIC (SHANGHAI) CO LTD

US **USA**
LOVATO ELECTRIC Inc.

UAE **United Arab Emirates**
LOVATO ELECTRIC ME FZE

HR **Croatia**
LOVATO ELECTRIC d.o.o.

D **Germany**
LOVATO ELECTRIC GmbH

E **Spain**
LOVATO ELECTRIC S.L.U.

CZ **Czech Republic**
LOVATO ELECTRIC S.R.O

TR **Turkey**
LOVATO ELEKTRİK LTD

CA **Canada**
LOVATO ELECTRIC Corp.

RO **Romania**
LOVATO ELECTRIC SRL

CH **Switzerland**
LOVATO ELECTRIC AG

BRA **Brasil**
LOVATO ELECTRIC DO BRASIL LTDA



LOVATO ACADEMY runs our client training programme.

Located at our Bergamo offices in ITALY, the classroom is equipped with the most recent audiovisual aids and interactive training benches and is the ideal place to learn about the use of our products and their programming and monitoring software.

academy.lovatoelectric.com





COMPANY PROFILE



ENERGY AND AUTOMATION

LOVATO ELECTRIC S.P. A.

via Don E. Mazza, 12
24020 Gorle (Bergamo), ITALY
tel +39 035 4282111

www.LovatoElectric.com



The products described in this document are subject to updates or modifications at any time. The descriptions, technical and functional information, illustrations and instructions in the leaflet are to be considered as purely illustrative and consequently have no contractual relevance. Remember also that the products themselves must be used by qualified personnel in compliance with current plant engineering and installation standards, in order to avoid injury to persons or damage to property.