

WHITE PAPER DC ENERGY METERS FOR EV CHARGING STATIONS TYPE DMED4

Compensation of energy losses generated
by the electric vehicle charging cable



PURPOSE OF THE DOCUMENT

The purpose of this document is to explain how LOVATO Electric energy meters type DMED4 perform the compensation of energy losses generated by the electric vehicle charging cable.

COMPENSATION OF LOSSES GENERATED ALONG THE CABLE

The image below shows the equivalent circuit of the electric vehicle charging station.

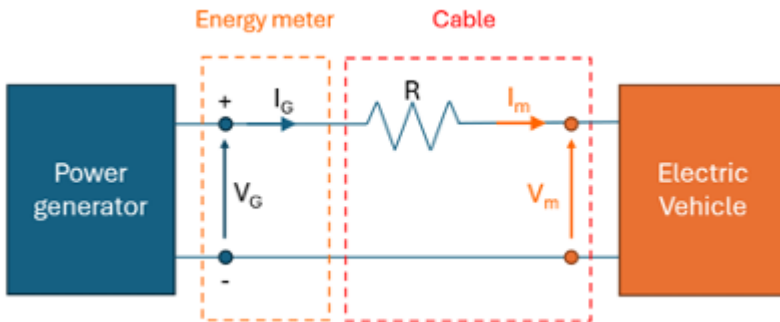

- V_G = voltage measured downstream of the charging station power unit
- I_G = generated current
- R = cable resistance
- I_m = current flowing inside the vehicle
- V_m = voltage at the cable connection point in the vehicle.

The energy injected into the vehicle during charging measured downstream of the charging station power unit, depends on the resistance of the charging cable (R), which causes a loss due to the voltage drop across it.

In the typical two-wire measurement scheme, the energy meter measures the voltage at the supply point (V_G) and the current at the supply point (I_G).

The current flowing into the electric vehicle (I_m) is clearly equal to the generated current I_G , as they are connected in series.

$$I_G = I_m = I$$

This does not apply to the voltage: due to the resistance of the cable, the voltage measured at the connection point of the cable in the electric vehicle (V_m) will not be equal to the voltage measured downstream of the charging station power unit (V_G), but will be lower, due to the voltage drop across the cable.

This voltage drop depends on the value of the cable's resistance, according to the following relationship:

$$V_m = V_G - R * I$$

The power consumed during charging is calculated using following equation:

$$P = V_m * I = (V_G - R * I) * I$$

Finally, the energy is calculated by integrating the power over time (T = charging time):

$$E = \int_0^T P(t)dt$$

As can be observed, if the value of the cable resistance R changes, the value of the power - and consequently the measured energy - also changes.

For this reason, it is essential that the energy meter can compensate for the energy loss caused by the cable, to correctly account for the energy delivered to the vehicle.

THE LOVATO ELECTRIC SOLUTION

To meet this requirement, LOVATO Electric DMED4 energy meters include in their firmware a dedicated parameter for compensating these losses (*P1.01 – Cable Compensation*).

This parameter allows the user to enter the nominal resistance value R of the charging station’s cable, which is then used to calculate the energy dissipated during the charging process.

Parameter list		UdM	Default	Range
P1.01	Cable compensation	mOhm	0	0...50
P2.01	OBIS mode		ON	OFF-ON
P2.02	Measure rotation		ON	OFF-ON
P2.03	Exported energy		OFF for DMED4D ON for DMED4R	OFF-ON

The resistance value of the charging cable is included in the charging report digitally signed by the energy meter (OCMF file), along with all other information required to complete the charging session record. This ensures that the energy measurement performed during charging has been calculated correctly.

This parameter can only be modified when the energy meter is set to commissioning mode and cannot be changed while in charging mode.

Inside the DMED4 energy meters, there is a non-erasable logbook dedicated to metrological events, which records all events that affect the metrological chain.

Among these events is the modification of the charging cable compensation value, which is logged with a timestamp (date and time) and permanently stored with no possibility of deletion.

Code Codice	Name Nome	Description Descrizione
1	EV_CABLE_COMPENSATION_CHANGED	Cable compensation change Modifica compensazione cavo

In the case where the DMED4 energy meter is wired using a 4-wire measurement configuration - i.e., with two additional wires dedicated exclusively to measuring the voltage at the supply point and not carrying current (and therefore unaffected by the voltage drop across the charging cable resistance) - it is sufficient to set parameter P1.01 to 0 mΩ.

This solution was verified and approved by NMI Certin B.V. and included in test reports NMI-3730246 belonging to the technical file of certificate T12924-DE concerning German Mess und Eichgesetz and the Mess und Eichverordnung.

Note. The NMI test reports refer to Welmec Guide 7.2, a technical document providing guidelines for the application of the Measuring Instruments Directive 2014/32/EU (MID) and Eichrecht in relation to legally regulated measuring instrument software, which includes DMED4 energy meters.

Below are two excerpts related to the topic of cable compensation.

In the section P3, related to the influence via user interface on parameters and measurement data, it is explicitly mentioned: The only parameter that can influence measurements is the **cable resistance loss** (P01.01), which **can only be adjusted when the device is not in "charging" status** and the global system status is different from "operating".

All changes to cable loss compensation are recorded in a log file for traceability.

Requirement		Passed	Failed	Not applicable	Remarks
P3	Influence via user interface(s) Commands entered via the user interface shall not inadmissibly influence the legally relevant software, device-specific parameters and measurement data.	X			
	Specifying notes:				
	1. There shall be an unambiguous assignment of each command to an initiated function or data change.	X			
	2. Commands that are not documented shall have no effect on legally relevant software, device-specific parameters and measurement data.	X			
	3. The modules that interpret commands are considered to be legally relevant software.	X			
	Remarks:				
	1. The primary functionality of the Human Machine Interface (HMI) is to browse measurements and device information, as outlined in the user manual.				
	2. Users can execute specific commands through the HMI, as detailed in both the user manual (under the "Advanced Functions" chapter) and the software description documents (refer to the "Menu and Password Management" chapter). These commands are clearly displayed with unique identifiers (e.g., CLEAR Chg, CLEAR h), ensuring clarity in operation.				
	3. None of the available commands can alter the metrologically significant measurement of <u>total active energy during the charging cycle or while the device is in "operation" status.</u>				
	4. The only parameter that can influence measurements is the cable resistance loss (P01.01), which can only be adjusted when the device is not in "charging" status and the global system status is different from "operating." All changes to cable loss compensation are recorded in a log file for traceability.				
	5. The HMI does not permit access to modify calibration factors, total active energy counters, LED pulse constants, or any other critical parameters, thereby safeguarding the integrity of the measurement system.				
	Reference : SWD00A0621.pdf Chapter 3.2.9, section "Serial RS-485 communication" I693IG007_24.pdf, chapter "Advanced function"				

Requirement		Passed	Failed	Not applicable	Remarks
P7	Parameter protection Device-specific parameters shall be protected against intentional modifications.	X			
	Specifying notes:				
	1. Certain device-specific parameters may be set by the user, provided that they are protected by a facility to automatically and non-erasable record any adjustment of the legally relevant device specific parameter, e.g., an audit trail.	X			
	2. If necessary for the purpose of verification of a measuring instrument, display or printing of the current relevant parameter settings shall be possible.	X			
	3. The records that provide evidence of an intervention shall be made available via display or printout upon command.	X			
	Remarks:				
	Device-specific parameters can be adjusted exclusively when the device is in " Hardware Test ON " mode. Accessing this mode requires unsealing the instrument housing, ensuring security and integrity.				
	The modification of the cable compensation loss parameter is logged in the metrological events log and is permitted under the following conditions:				
	1. The device must be in " Commissioning " status mode.				
	2. No active charging cycle should be in progress.				
	Reference : SWD00A0621.pdf Chapter 3.8 "Calibration procedure"				

In the section P7, related to parameter protection against intentional modification, it is mentioned: "The modification of the cable compensation loss parameter is logged in the metrological events log and is permitted under the following conditions:

1. The device must be in "Commissioning" status mode.
2. No active charging cycle should be in progress."

In summary:

- It is possible to set the resistance value of the charging cable used within the energy meter, to account for the energy actually consumed by the vehicle, compensating for the losses due to the cable.
- Any modification of the charging cable resistance parameter is permanently logged with a timestamp (date and time) within the energy meter's metrological event logbook.

Thanks to this solution, the software of the charging station is not subject to metrological verification concerning the modification of the cable resistance value.

Furthermore, adjusting the resistance value allows for the management of different types of cables with a single product, ensuring maximum flexibility of use.



WHITE PAPER
DMED4



LOVATO ELECTRIC S.P. A.

via Don E. Mazza, 12
24020 Gorle (Bergamo), ITALY
tel + 39 035 4282111
info@LovatoElectric.com

www.LovatoElectric.com



The products described in this publication are subject to be revised or improved at any moment. Catalogue descriptions and details, such as technical and operational data, drawings, diagrams and instructions, etc., do not have any contractual value. In addition, products should be installed and used by qualified personnel and in compliance with the regulations in force for electrical systems in order to avoid damages and safety hazards.